



Enriching Lives

MULTISTAGE PUMPS

TYPE - RKB



CE

KIRLOSKAR BROTHERS LIMITED

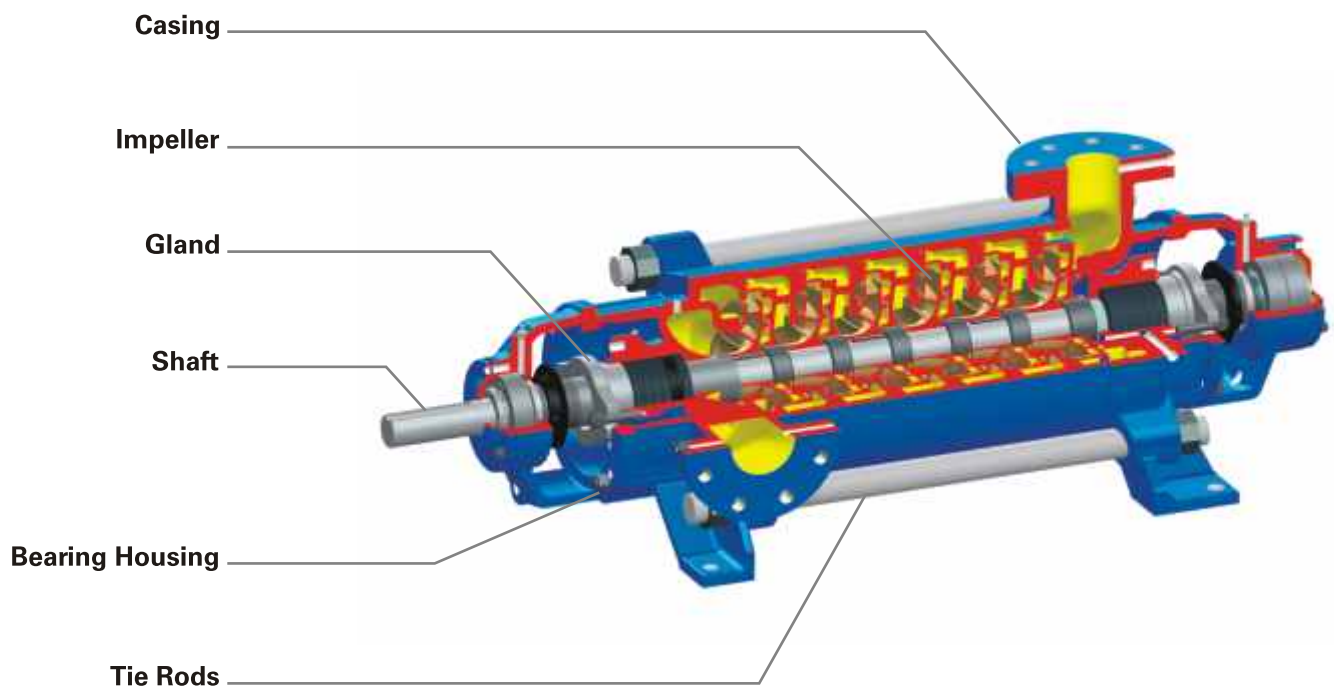

RANGE

Delivery size : up to 250 mm
 Capacity : up to 850 m³/hr
 Head : up to 850 metres

APPLICATIONS

Sprinkler Irrigation, Fire Fighting, Water Supply to high rise buildings, Descaling, Mine Dewatering and Boiler Feed

FEATURES

This pump consists of a number of ring section diffuser casings bolted suction and delivery casing. Various models are available to operate at 1450 rpm and 2900 rpm at 50 Hz power supply frequency.

Casing :

Latest casing techniques ensure smoothness of hydraulic passages resulting in high efficiency and reliability under hazardous conditions. The delivery flange is vertical. The suction flange can be oriented left or right viewed from driving end.

Impeller :

The enclosed impellers of the radial flow type are provided with balancing holes to balance the hydraulic axial thrust. The rotating elements are statically and dynamically balanced.

Shaft :

The high tensile steel shaft accurately machined and ground is supported by antifriction bearings that take the residual axial thrust and prevent axial float or radial run out. The shaft is protected by shaft sleeve from wear in stuffing box area.

Stuffing Box :

The stuffing box can be sealed by gland packing or by mechanical seal with minor modification. While pumping high temperature liquids from 90°C to 140°C, cooling jacket is provided for the stuffing box.

Bearing :

Standard lubrication is grease. For temperature above 90°C and upto 140°C - oil lubrication is required.

Direction of Rotation :

Standard : Clockwise viewed from driving end.

Optional : Anticlockwise viewed from driving end.

Drive :

These pumps are suitable for coupling with electric motors, I C engines or steam turbine either directly or through belt drives.

Flanges :

	Standard	Optional
Suction Flange	DIN ND - 10	ASA 125, 150 BS 4504-16/11
Delivery Flange	DIN ND - 40 or ND - 64	ASA 250, 300 or 800 BS 4504-16/11

GENERAL DIMENSIONS

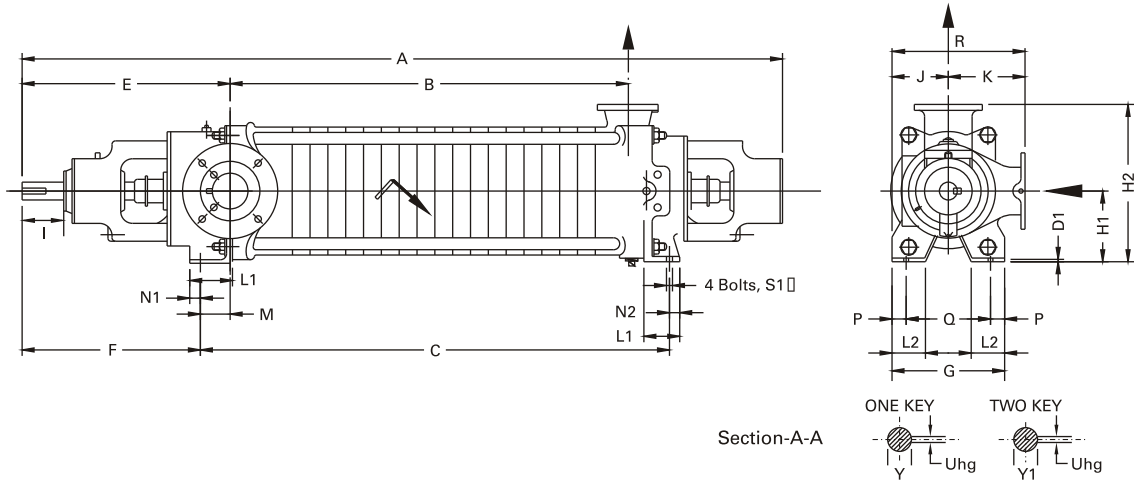

Pump Model - RKB 32-9E															
No. of Stages															
c/s.	50 & 60											50			
	140 rpm														
A	582	629	676	723	770	817	864	911	958	1005	1052	1099	1146	1193	1240
B	117	164	211	258	305	352	399	446	493	540	587	634	681	728	775
C	207	254	301	348	395	442	489	536	583	630	677	724	771	818	865
Wt.kg.	53	60	67	73	80	87	93	100	107	113	120	127	134	141	148
P'															

Pump Model - RKB 40-12L 40-14H															
No. of Stages															
c/s.	50 & 60											50			
	A	631.5	686.5	741.5	796.5	851.5	906.5	961.5	1016.5	1071.5	1126.5	1181.5	1236.5	1291.5	
B	137	192	247	302	357	412	467	522	577	632	687	742	797		
C	242	297	352	407	462	517	572	627	682	737	792	847	902		
Wt.kg.	85	95	105	115	125	135	145	155	165	175	185	195	205		
P'	180														

Pump Model - RKB 50-15E/L 50-16H															
No. of Stages															
c/s.	50 & 60											50			
	A	745	805	865	925	985	1045	1105	1165	1225	1285	1345	1405	1465	
B	160	220	280	340	400	460	520	580	640	700	760	820	880		
C	280	340	400	460	520	580	640	700	760	820	880	940	1000		
Wt.kg.	106.5	118	129.5	141	152.5	164	175.5	187	198.5	210	221.5	233	244.5		
P'	190														

Pump Model - RKB 65-19E/L																
No. of Stages																
c/s.	50 & 60							50				50				
	A	875	951	1027	1103	1179	1255	1331	1407	1483	1559	1635				
B	206	286	358	434	510	586	662	738	814	890	966					
C	341	417	493	569	645	721	797	873	949	1025	1101					
Wt.kg.	155	175	195	215	235	255	275	295	315	335	355					
P'																

Pump Model - RKB 65-24									
No. of Stages									
c/s.	50 & 60								9
	A	1226	1296	1366	1436	1506	1576	1646	1716
B	195	265	335	405	475	545	615	685	
C	299	349	399	449	499	549	599	649	
Wt.kg.	563	614	665	716	767	818	869		
P'									

Pump Model - RKB 100-23E/M																
No. of Stages																
c/s.	50 & 60							50				50				
	140 rpm															
A	996	1096	1196	1296	1396	1496	1596	1696	1796	1896						
B	260	360	460	560	660	760	860	960	1060	1160						
C	385	485	585	685	785	885	985	1085	1185	1285						
Wt.kg.	280	320	360	400	440	480	520	560	600	640						
P'																

Pump Model - RKB 125-27 and 125-27M															
No. of Stages															
c/s.	50 & 60											50			
	A	1089.5	1199.5	1309.5	1419.5	1529.5	1639.5	1749.5	1859.5	1969.5	2079.5	2189.5	2299.5	2409.5	
B	295	405	515	625	735	845	955	1065	1175	1285	1395	1505	1615		
C	401	511	621	731	841	951	1061	1171	1281	1391	1501	1611	1721		
Wt.kg.	319	376	433	490	547	604	661	718	775	832	889	946	1003		
P'															

Pump Model - RKB 125-30																
No. of Stages																
c/s.	50 & 60							50								
	A	1165.8	1285.8	1405.8	1525.8	1645.8	1765.8	1885.8	2005.8	2125.8	2245.8	2365.8	2485.8			
B	325	445	565	685	805	925	1045	1165	1285	1405	1525	1645				
C	430	550	670	790	910	1030	1150	1270	1390	1510	1630	1750				
Wt.kg.	410	484	558	632	706	780	854	928	1002	1076	1150	1224				
P'																

Pump Model - RKB 150-34															
No. of Stages															
c/s.	50 & 60											50			
	A	1293	1428	1563	1698	1833	1968	2103	2238	2373	2508	2643			
B	365	500	635	770	905	1040	1175	1310	1445	1580	1715				
C	460	595	730	865	1000	1135	1270	1405	1540	1675	1810				
Wt.kg.	595	697	799	901	1003	1105	1207	1309	1411	1513	1615				
P'															

Pump Model - RKB 200-37																
No. of Stages																
c/s.	50 & 60							50								
	A	1374	1519	1664	1809	1954	2099	2244	2389	2534	2679					
B	405	550	695	840	985	1130	1275	1420	1565	1710						
C	520	665	810	955	1100	1245	1390	1535	1680	1825						
Wt.kg.	753	893	1033	1173	1313	1453	1593	1736	1879	2022						
P'																

Pump Model - RKB 32-14H														
No. of Stages														
c/s.	50 & 60													
	A	524	567	610	653	696	739	782	825	868	911	954	997	1040
B	114	157	200	243	286	329	372	415	458	501	544	587	630	673
C	264	307	350	393	436	479	522	565	608	651	694	737	780	823
Wt.kg.	75	84	93	102	111	120	129	138	147	156	165	174	183	192
P'														

CROSS-SECTIONAL VIEW

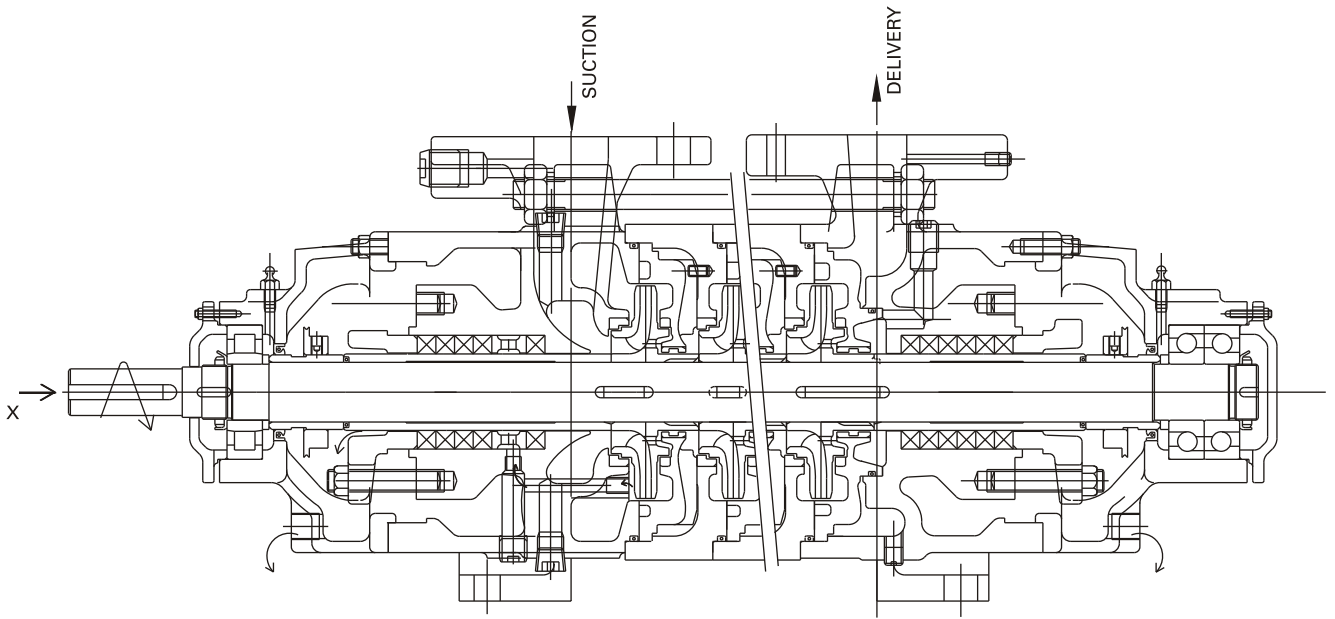

ORIENTATION / ROTATION

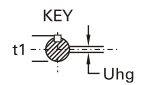
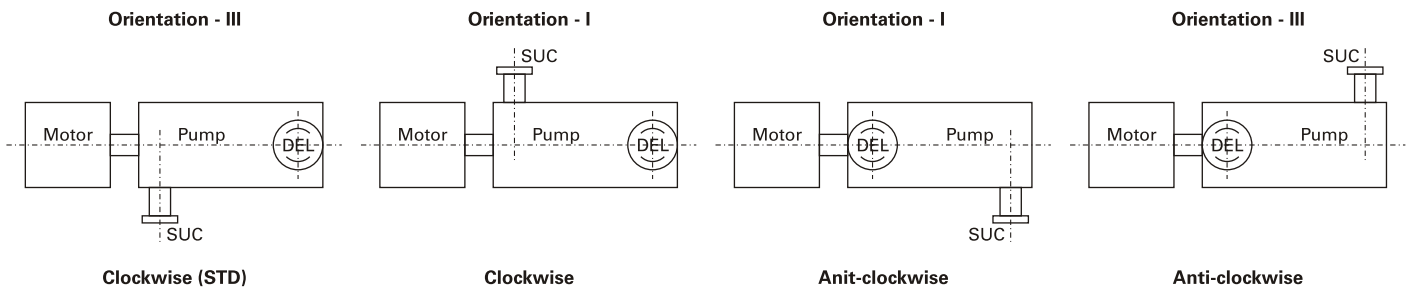

MOUNTING DETAILS

Pump Dimensions																																			
Sr. no.	Pump Type	SUC	DEL	E	F	N1	L1	H1	H2	T Thk	J	K	R	G	Q Crs	N2	L2	No. of holes S1	d10	Shaft Details					SUC. Flanges				DEL. Flanges						
																				Do	U hg	I	t1	Y1	PN10				PN40		PN64				
																									S	d0	F	T2	T1 Thk	S'	d0	F'	S'	d'0	F'
1	RKB 32-9E	40	32	269.5	209.5	15	60	112	252	14	105	140	245	210	180	15	60	4	14	25j6	8	60	28	-	4	18	110	18	23	4	15	100	-	-	-
2	RKB 40-12L	50	40	274	218	15	60	125	275	14	130	150	280	260	230	18	60	4	14	30k6	8	60	33	-	4	18	125	20	23	4	18	110	-	-	-
3	RKB 50-15E/L	65	50	330	265	20	70	135	315	15	140	180	320	280	240	20	65	4	19	35k6	10	80	38	-	4	18	145	20.5	25	4	18	125	-	-	-
4	RKB 65-19E/L	80	65	393	326	20	70	180	380	15	180	200	380	360	315	20	70	4	19	40k6	12	110	43	46	8	18	160	21	33	8	18	145	8	22	160
5	RKB 65-24	80	65	565	464	15	100	250	550	25	230	300	530	460	360	45	100	4	24	60m6	18	90	64	68	8	18	160	51	33	8	18	145	8	22	160
6	RKB 100-23E	125	100	407	327	30	80	215	490	18	205	275	480	420	360	30	80	4	24	45k6	14	110	48.5	52	8	18	210	26	38	8	22	190	8	26	200
7	RKB 125-27	150	125	435.5	379.5	40	100	250	565	25	245	315	560	490	400	40	100	4	24	50k6	14	110	53.5	57	8	22	240	28	45	8	26	220	8	30	240
8	RKB 125-30	150	125	453.8	404.9	40	100	280	630	25	250	350	600	530	440	40	100	4	26	55m6	16	110	59	63	8	22	240	28	45	8	26	220	8	30	240
9	RKB 150-34	200	150	511.5	476.5	40	100	300	700	25	278	400	678	550	460	40	100	4	26	60m6	18	140	64	68	8	22	295	30	55	26	250	8	33	280	
10	RKB 200-37	250	200	537	497	40	110	350	850	28	320	500	820	630	550	40	110	4	26	65m6	18	140	69	73	12	22	350	32	54	12	30	320	12	36	345
11	RKB 250-46	300	250	781	790	40	65	450	1050	48	400	600	1140	790	650	70	140	4	42	90m6	25	170	100	100	16	33	450	48	50	12	33	450	-	-	-

All dimensions are in mm

MATERIALS

MATERIAL OF CONSTRUCTION

Casing Suction / Discharge / Stage	Cast Iron / Cast Steel / Stainless Steel / Duplex Steel
Impeller	Cast Iron / Bronze / Phosphor Bronze / Cast Steel / Stainless Steel / Chrome Steel / Duplex Steel
Diffuser	Cast Iron / Bronze / Phosphor Bronze / Cast Steel / Stainless Steel / Chrome Steel / Duplex Steel
Casing wear Ring	Cast Iron / Bronze / Steel
Shaft	Carbon Steel / Stainless Steel
Shaft Sleeve	Stainless Steel / Bronze

MATERIAL STANDARDS

Material Type	Indian Standard (IS)	American Standard (ASTM)	DIN
Cast Iron			
Cast Iron	IS 210 Gr. FG 260	ASTM A48 Class 40	(0.6025)DIN 1691 GG25
Spheroidal Graphite Cast Iron			
SG Iron (Ductile Iron)	IS 1865 Gr 400/15	A536, 60-40-18	(0.7040)DIN1693 GGG40
SG Iron (Ductile Iron)	IS 1865 Gr 500/7	A536, 65-45-12	(0.7050)DIN1693 GGG50
Carbon Steel			
Carbon steel (Wrought)	IS 1570 (part II) Gr. 40C8	ASTM A107 Gr. 1040	(1.1186)C40E/CK40
Carbon steel (Wrought)	IS 1570 (part II) Gr. 20C8	ASTM A107 Gr. 1020	(1.0402)C22
MS Steel	MS IS 2062 - Fe 410 W A	ASTM-A283 GR.D	DIN 1700 GR ST4-2 FABRICATED STEEL44
Cast Steel Grades			
Cast Steel		ASTMA 216 Gr. WCB	1.0619(GS-C25)
Cast Stainless Steel			
Stainless Steel CF8M	IS 3444 Gr. 4	ASTMA 351 Gr. CF8M	1.4408(GX5CrNiMo19-11-2)
Stainless Steel CF8M	IS 3444 Gr. 4	ASTMA 743 Gr. CF8M	1.4408(GX5CrNiMo19-11-2)
Stainless Steel CF3M	IS 3444 Gr. 16	ASTMA 351 Gr. CF3M	1.4409(GX2CrNiMo19-11-2)
Stainless Steel CF3M	IS 3444 Gr. 16	ASTMA 743 Gr. CF3M	1.4409(GX2CrNiMo19-11-2)
Stainless Steel CF8	IS 3444 Gr. 1	ASTMA 351 Gr. CF8	1.4301(X5CrNi18-10)
Stainless Steel CF3	IS 3444 Gr. 15	ASTMA 351 Gr. CF3	1.4306(X2CrNi19 11)
Cast Chromium Stainless Steel			
Stainless Steel CA15	IS 3444 Gr. 10	ASTMA 217 Gr. CA15	1.4106&1.448(DIN17445 GX12Cr14)
Stainless Steel CA15	IS 3444 Gr. 10	ASTMA 743 Gr. CA15	1.4106&1.448(DIN17445 GX12Cr14)
Stainless Steel CA6NM	IS 3444 Gr. 24	ASTMA 487 Gr. CA6NM	1.4313&1.4317(GX5CrNiMo13-4)
Stainless Steel CA6NM	IS 3444 Gr. 24	ASTMA 743 Gr. CA6NM	1.4313&1.4317(GX5CrNiMo13-4)
Chromium Stainless Steel Round Bar Material			
Stainless steel 410	IS 1570 (part V) Gr. X12Cr12	ASTMA 276 type 410	1.4006(X10Cr13)
Stainless steel 420	IS 1570 (part V) Gr. X20Cr13	ASTMA 276 type 420	1.4021(X20Cr13)
Stainless steel 431	IS 1570 (part V) Gr. X15Cr16Ni2	ASTMA 276 type 431	1.4057(X20CrNi17)
Stainless steel 316	IS 1570 (part V) Gr. X04Cr17Ni12Mo2	ASTMA 276 type 316	1.4401(X5CrNiMo17122)
Stainless steel 316L	IS 1570 (part V) Gr. X02Cr17Ni12Mo2	ASTMA 276 type316L	1.4404(X2CrNiMo1810)
Cast Duplex Steel			
Duplex Steel 1A		ASTMA 890 Gr. CD4MCu	25Cr-5Ni-Mo-Cu
Duplex Steel 2A		ASTMA 890 Gr. CE8MN	24Cr-10Ni-Mo-N
Duplex Steel 3A		ASTMA 890 Gr. CD6MN	25Cr-5Ni-Mo-N
Super Duplex steel 4A		ASTMA 890 Gr. CD3MN	25Cr-7Ni-Mo-N
Super Duplex steel 5A		ASTMA 890 Gr. CE3MN	24Cr-10Ni-Mo-N
Non Ferrous Materials			
Bronze	IS 318 Gr. LTB2 (CuSn5Zn5Pb5C)	ASTMB 584 - C90500	DIN 1705 Rg 5
Phosphor Bronze	IS 28 Gr. 1 (CuSn11PC)		
Zinc Free Bornze	IS 28 Gr. 1 (CuSn10C)		

OUTLINE DRAWING OF RKB MULTI-OUTLET PUMPS

RKB Multi-outlet arrangement is normally used when capacity is fixed and total head changes time to time, without disturbing the pump's internals. Available with option of two or three outlets depending upon the requirement.

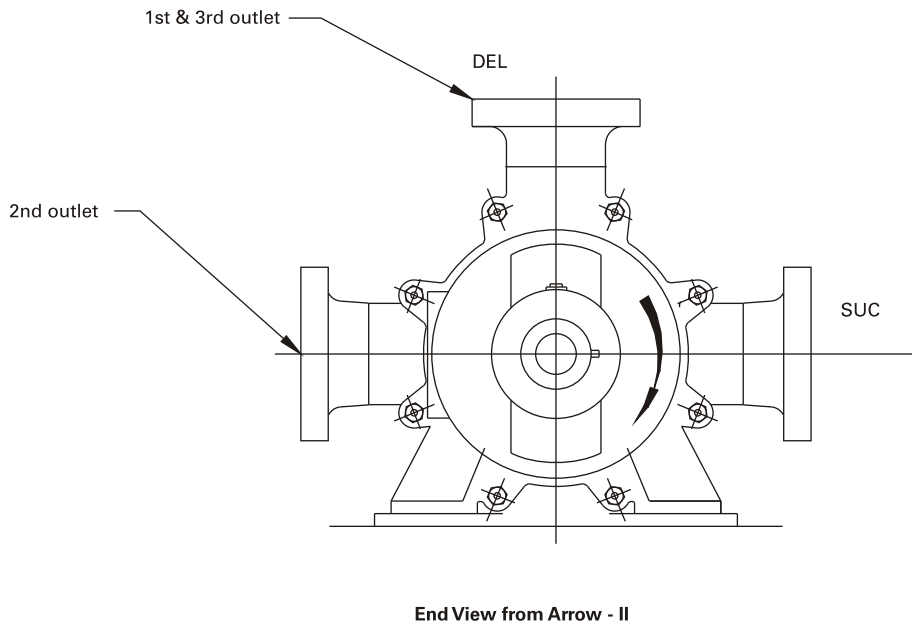
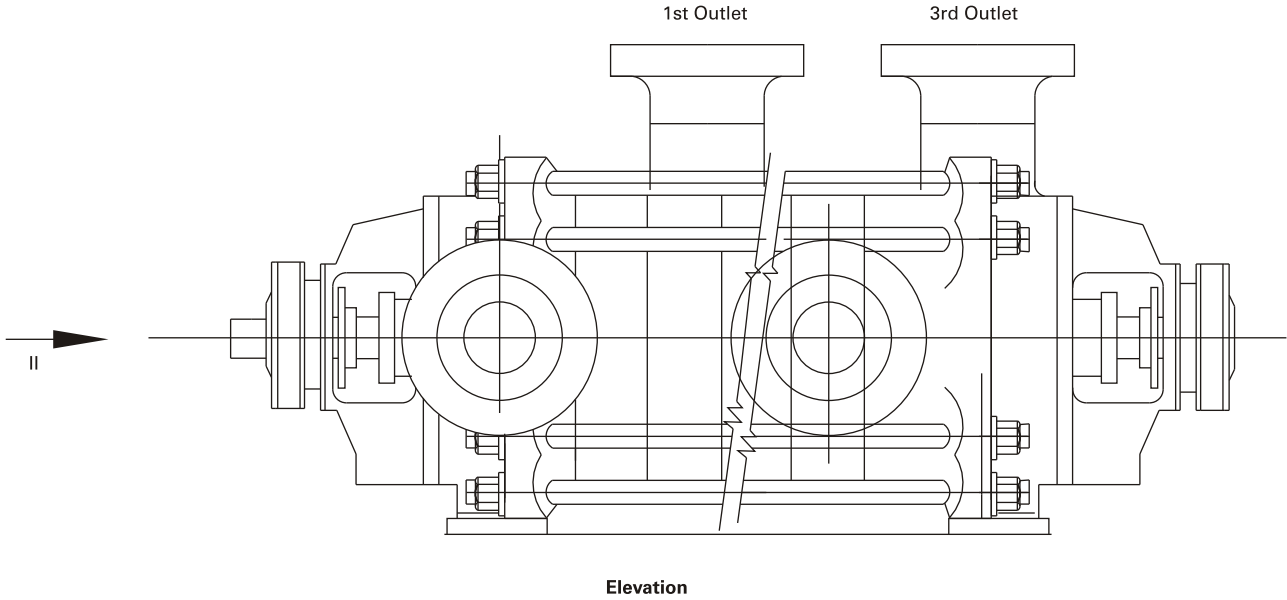

OUTLINE DRAWINGS

RKBCV Pump

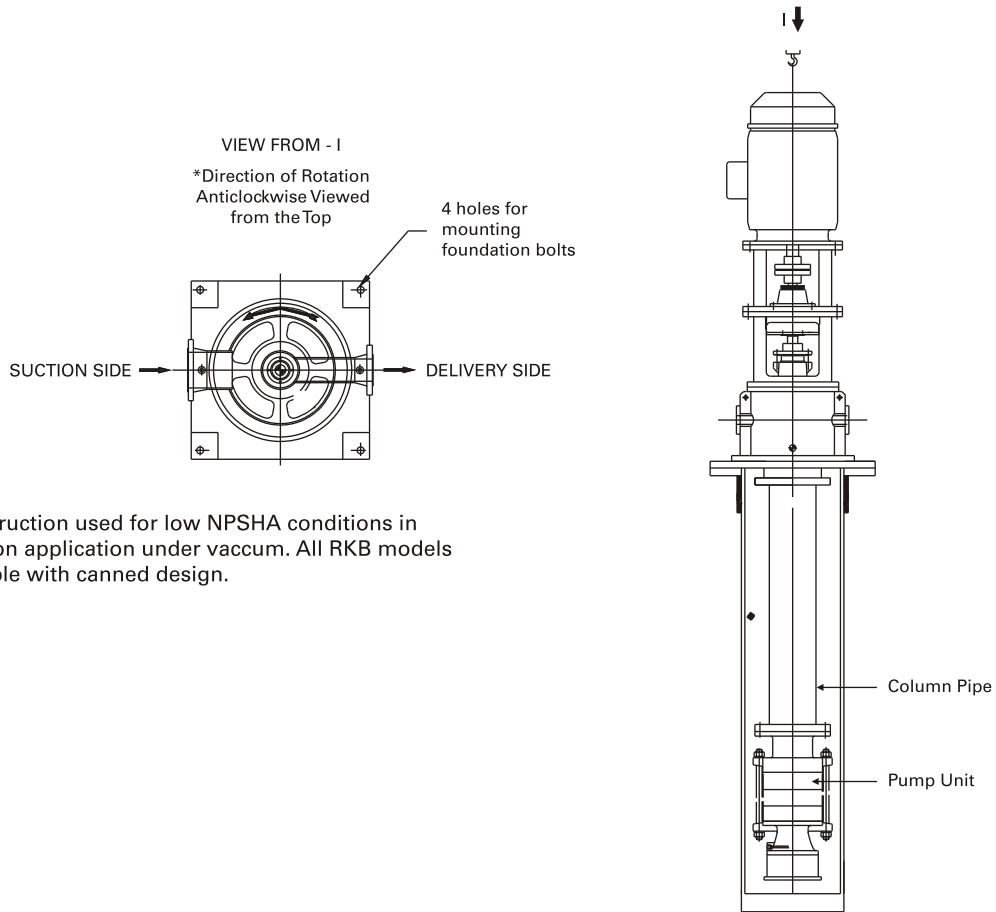

Canned pump construction used for low NPSHA conditions in condensate extraction application under vacuum. All RKB models can be made available with canned design.

RKBS Pump

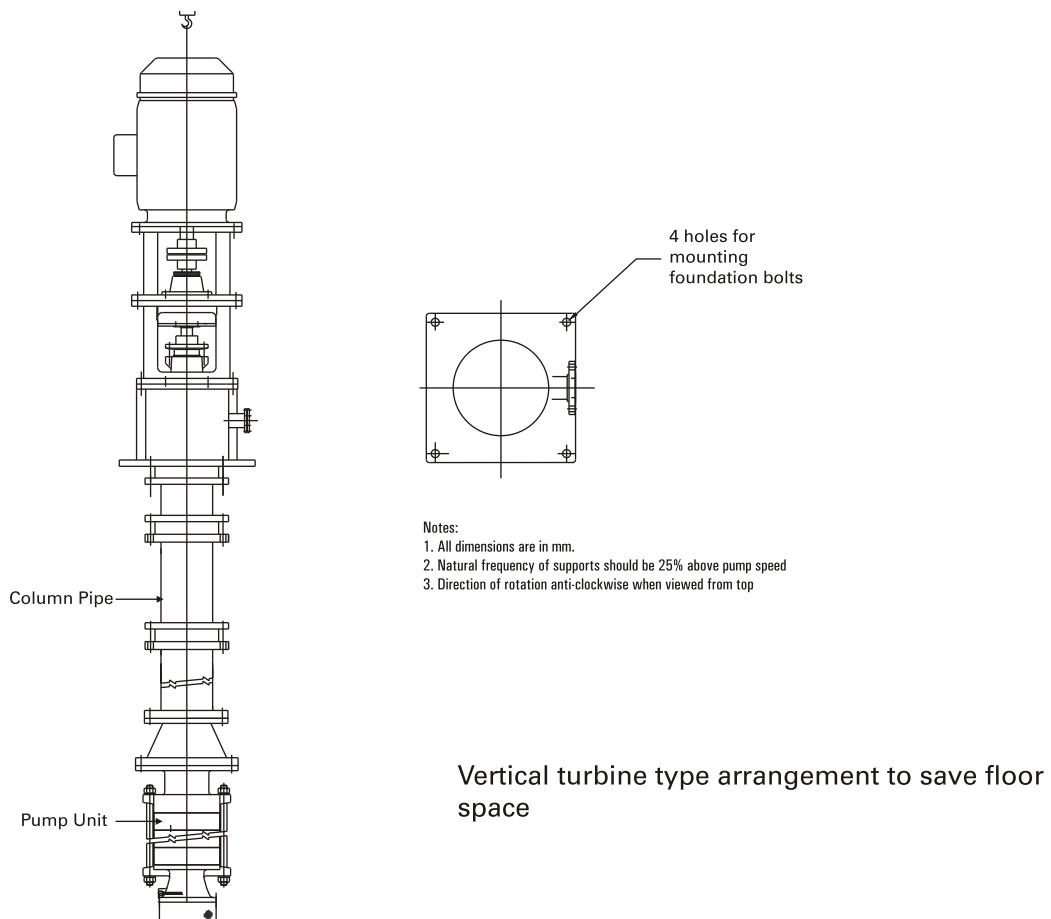

Pump at 1450 rpm-50Hz

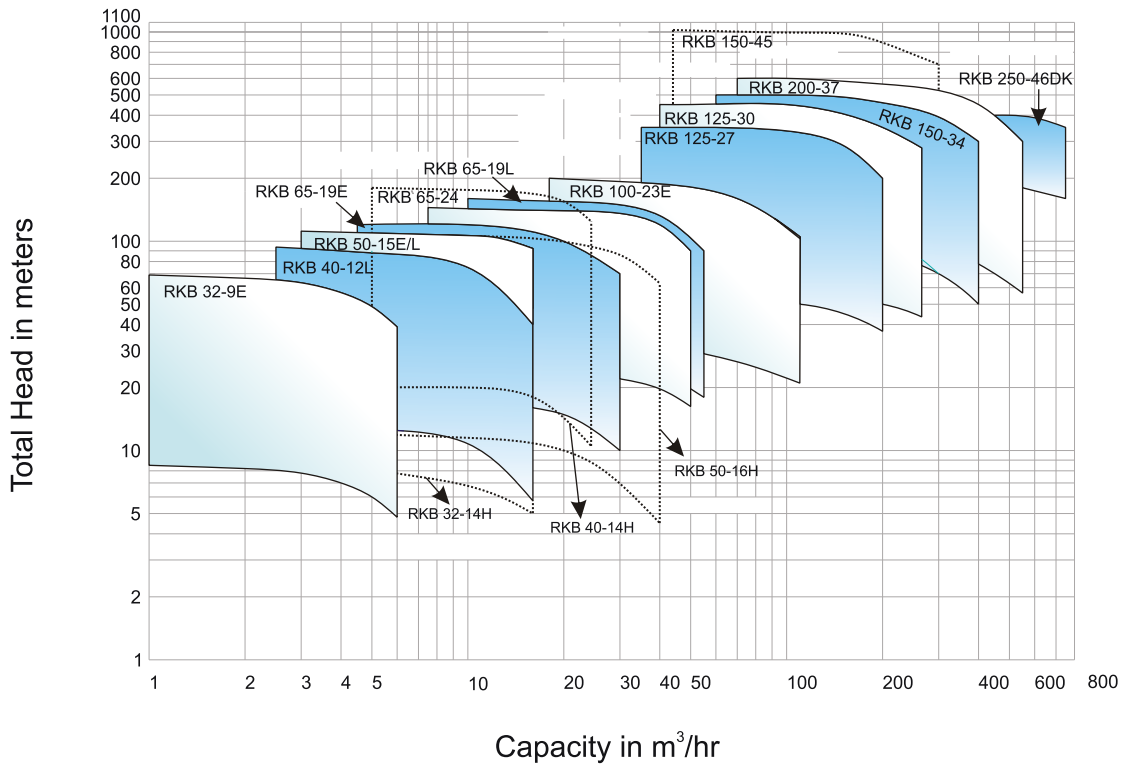

Pump at 2900 rpm-50Hz

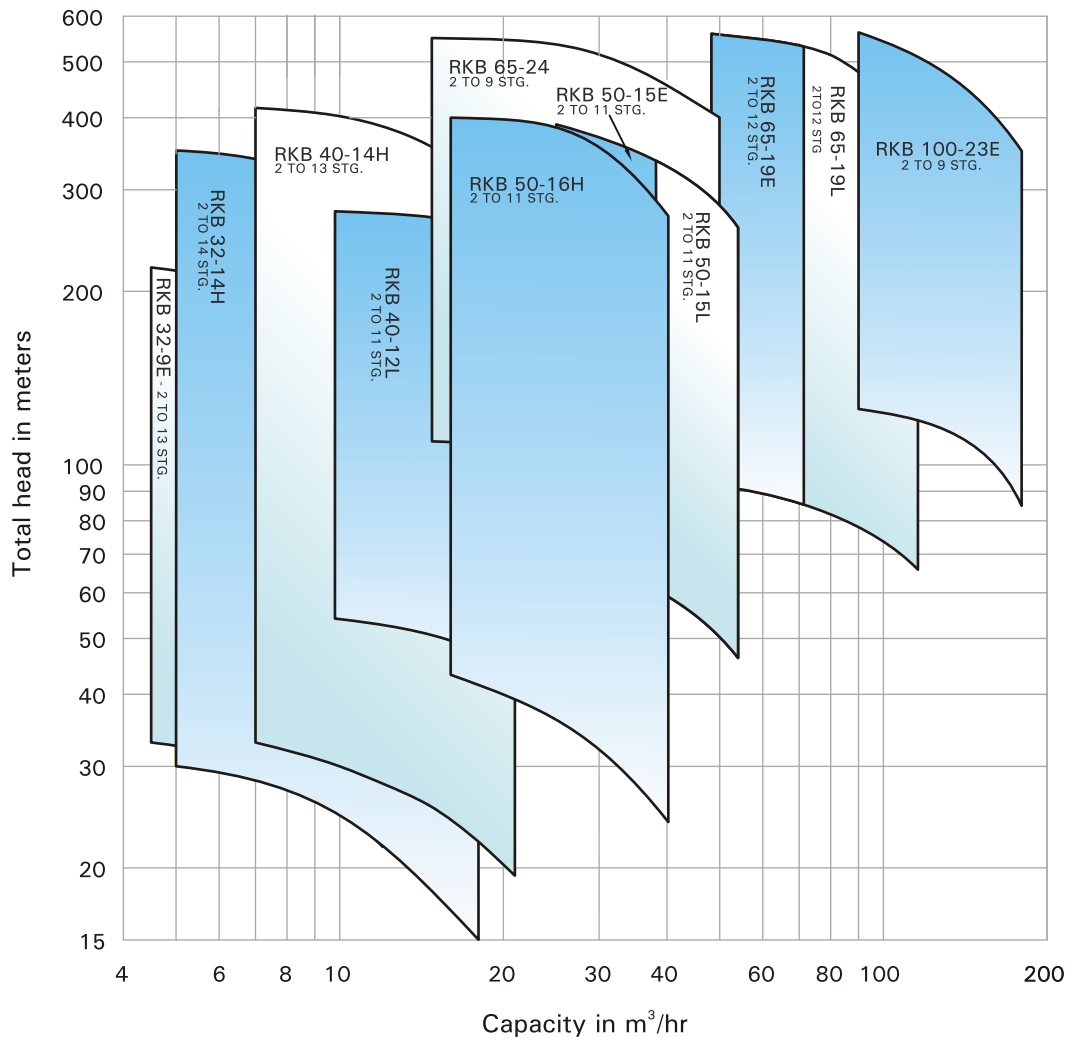

OUR GLOBAL PRESENCE



As we are constantly endeavouring to improve the performance of our products/ equipment, we reserve the right to make alterations from time to time and as such our products/ equipment may differ from that detailed in this publication. For latest information you may get in touch with our Regional Sales Offices.



Enriching Lives

KIRLOSKAR BROTHERS LIMITED

CORPORATE OFFICE :

"YAMUNA" Survey No. 98 (3/7), Baner,
Pune - 411045, INDIA
Tel.: +91 20 27214444 Fax: +91 20 27211117
email: kbilin@kbl.co.in website: www.kbl.co.in

WORKS :

Kirloskarvadi 416308 Dist. Sangli
Maharashtra, INDIA
Tel.: +91 2346 222301 to 222305
Fax: +91 2346 222311

